

## AirPrime™ Overview and Features



“Quick, reliable pump priming...  
When you need it!”



World Class Fire Industry Products

## Contents

AirPrime™ - How Does It Work.....	2	Multi Location Automatic AirPrime™ System .....	5
Standard Features .....	3	Manual AirPrime™ System .....	6
New Installations .....	3	AirPrime™ SC .....	6
Retrofit Installations.....	3	Multi Location Manual AirPrime™ Systems.....	7
Automatic Priming System.....	4	AirPrime Models .....	8

## AirPrime™ - How Does It Work

### Air Powered Pump Primer

**AirPrime** utilizes air supplied from the chassis air brake system to operate the pump primer. This is proven to be far more efficient and reliable than conventional electric motor driven primers.

**AirPrime** virtually eliminates the impact load on the vehicles electrical system thereby improving reliability.

**AirPrime** improves performance in the elapsed time for establishing water supply, resulting in improved fireground operations and safety.

**AirPrime** has systems available for large flow industrial pumpers and trailers.

**AirPrime** is also available for use on vehicles without air brake systems.

**Auto Prime** Move Switch to the upper position. The Green LED light will illuminate. The primer will activate when the OK TO PUMP light is ON and the Pump Pressure is below 20 PSIG.

**The Auto Mode only operates when the fire pump is engaged.**

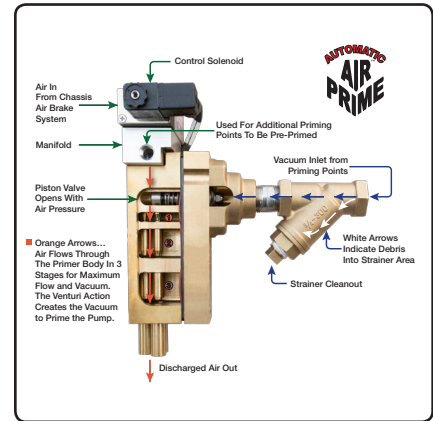

### Off Position

Incoming Air Flow **OFF**.

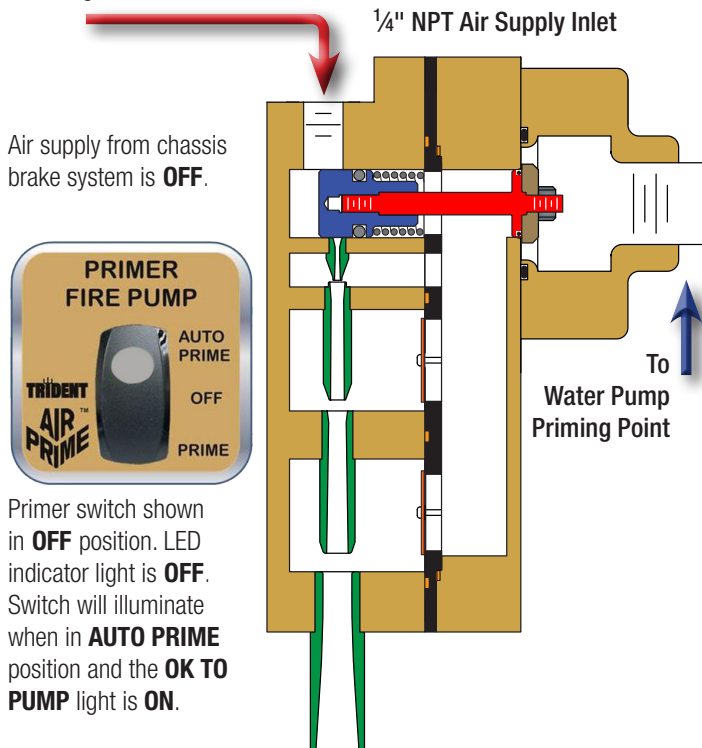

### Auto Prime Position

Incoming Air Flow **OPEN**.

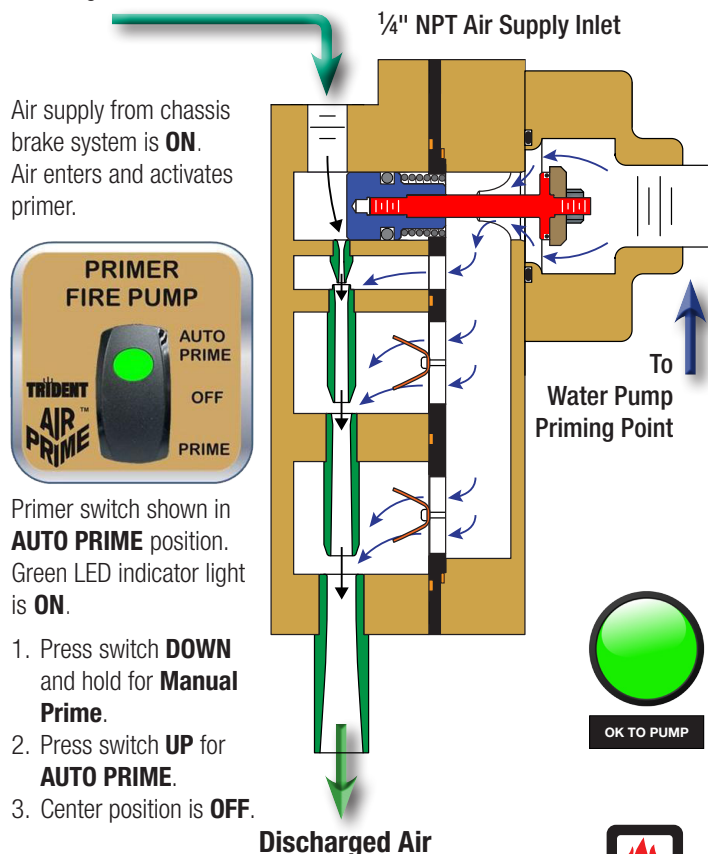

## Standard Features

- ▶ Reliable chassis air supplied by the engine driven air compressor
- ▶ No electric motor, solenoid valve, or heavy battery cables
  - ▶ Electric rotary vane primer = **300 amp draw on chassis electrical system**
  - ▶ Auto AirPrime™ = 0.4 amps
- ▶ Vertical lift capability to >27' [8 meters]
- ▶ Faster than an electric primer with lifts under 15' [5 meters]
- ▶ 4' lift from a Folding Tank in less than 10 seconds with engine at idle speed
- ▶ Quietest Primer Available
- ▶ Lowest cost in the industry
- ▶ Five Year Warranty, Unlimited duty cycle
- ▶ Non corrosive primer body construction
- ▶ Vacuum produced by venturi action within primer body
- ▶ Primer features automatic draining – No freezing
- ▶ Air only primer control lines (no water piping to pump panel – avoids freezing)
- ▶ No moving parts to create vacuum, minimal maintenance required
- ▶ No primer vanes to replace
- ▶ Requires no lubrication
- ▶ No need for an electric clutch and belt drive assembly

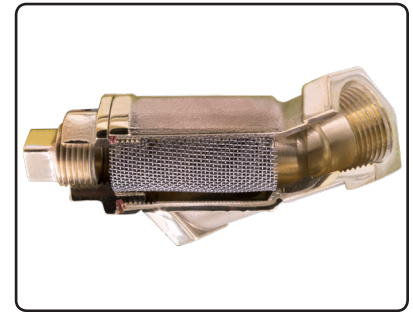

Separate and Cleanable Wye  
Stainless Steel Strainer Screen

## New Installations

- ▶ Installs in half the time as compared to an electric primer
- ▶ Mounting in any high location above the highest priming point within the pump enclosure
- ▶ Unique and easily identifiable control panel
- ▶ Perfect for multiple location gated intakes

## Retrofit Installations

- ▶ Takes less space and weighs less than rotary vane primers
- ▶ Weighs only 8.5 pounds [3.9 kg.]
- ▶ Requires an installation area of only 12" high x 4" wide
- ▶ No high amp draw on battery
- ▶ No primer water lines to pump panel
- ▶ Lowest noise level in the industry
- ▶ Installs on any fire pump
- ▶ Easy to retrofit in fire station by a mechanic
- ▶ Automatic AirPrime™ available
- ▶ Optional Lift Gauge on control panel
- ▶ Multiple priming location systems available
- ▶ Primer can be tested without fire pump being in gear

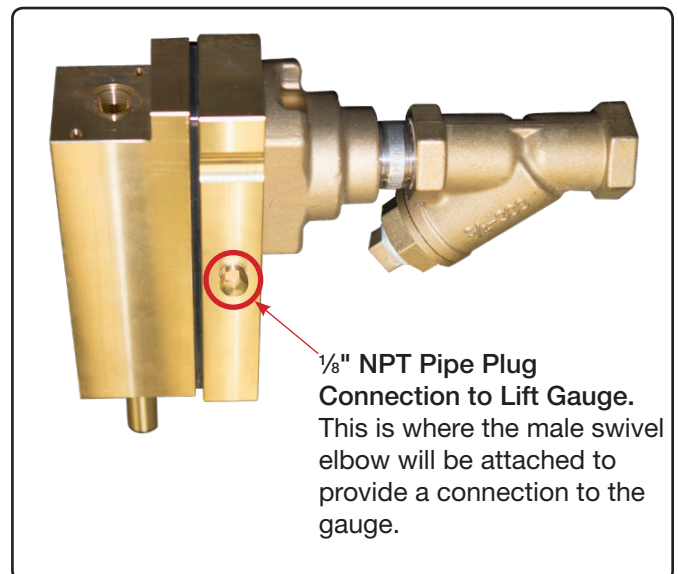

## Automatic Priming System

### Control Panel Rocker Switch Positions

- ▶ **AUTO PRIME Position:** Primer is automatically activated when the green OK TO PUMP light is ON and the pump pressure is less than 20 PSI [1.3 bar]. The Primer Control LED green light is ON.
- ▶ **OFF Position:** The primer is OFF.
- ▶ **PRIME Position:** To activate primer, Manually Push the switch down and hold. Also used for periodic testing of the priming system (even when fire pump is not in gear).



### Auto AirPrime™ – Works On

- ▶ All types of fire pumps
- ▶ Any GPM rating
- ▶ Perfect for cold northern climates
- ▶ Any type of chassis with an air brake system

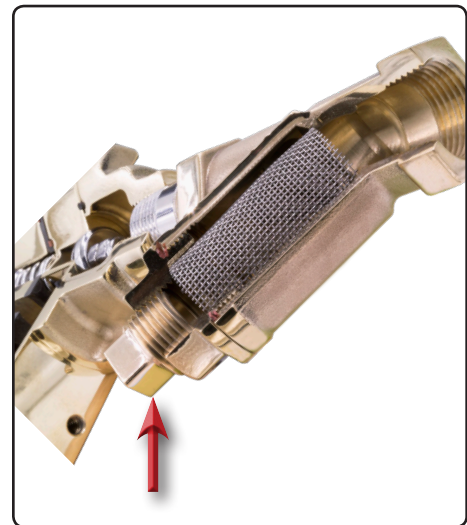

**Integral Stainless Steel Strainer**  
 Located on Primer Intake.  
 Replaceable Screen.  
 Shown With Red Arrow Above.

### Control Panel with Lift Gauge

- ▶ Optional gauge indicates the vertical elevation of water in feet when primer is operating
- ▶ Gauge is directly connected to the primer. Will not be damaged by positive pressure (hydrant) connection
- ▶ Used for periodic ramp test of primer
- ▶ No other primer in North America is available with an integral vacuum lift gauge

**Automatic AirPrime in Action ▶**  
 Ten sections of 6" suction hose (100') performing a 10' lift from a dry hydrant. One minute and 53 seconds to prime.



## Multi Location Automatic AirPrime™ System

### Auto AirPrime

Primer is automatically activated for re-priming when pump pressure drops below 20 PSI [1.3 bar]

- ▶ When a slug of air enters the impeller
- ▶ When LDH discharge valve is opened too fast
- ▶ Switching from tank water to another supply source
- ▶ Other intakes can be manually pre-primed even while the Auto AirPrime™ is still engaged
- ▶ Separate primer control panels for drafting operations at Left Side, Right Side, Front or Rear of apparatus



Tanker Shuttle Operations

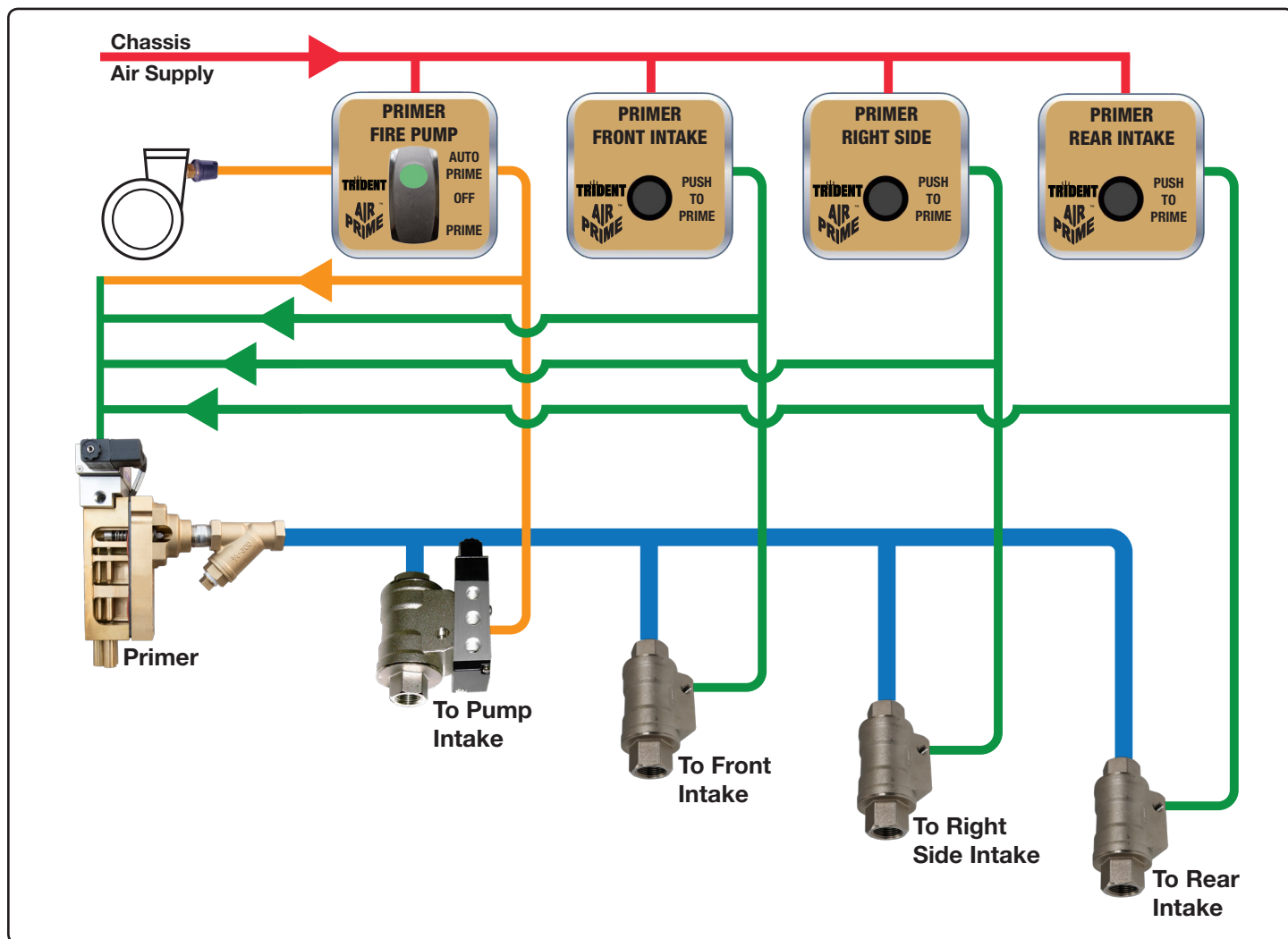
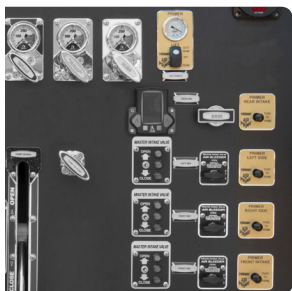

## Manual AirPrime™ System

### Standard Primer Panel

Depressing the **PUSH TO PRIME** button directs air to the primer inlet

- ▶ An internal air primer valve is opened with air pressure from chassis air system
- ▶ Vacuum for drafting is created by air-flow through multi-stage internal venturi nozzles
- ▶ Panel has no water piping or electrical wiring...  
Controlled by air, eliminates freezing and electrical problems

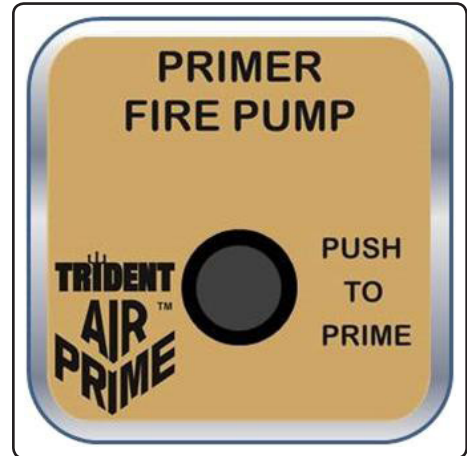

### Manual AirPrime™ – Features

- ▶ Mounting on any type of fire pump with any GPM rating
- ▶ No electric wiring, motors, or solenoids
- ▶ Works on any type of chassis with an air brake system
- ▶ Also available for NFPA 1901 Wildland Trucks without air brakes



### Control Panel with Lift Gauge

- ▶ Optional gauge indicates the vertical elevation of water in feet when primer is operating
- ▶ Gauge is directly connected to the primer. Will not be damaged by positive pressure (hydrant) connection
- ▶ Ability for periodic ramp test of primer

## AirPrime™ SC

AirPrime is now available for use on vehicles without an air brake system through use of a high pressure breathing air cylinder and a Trident Pressure Reducing Regulator.



### AirPrime Pressure Regulator

For use with high pressure SCBA cylinders  
Part Number 14.013.0



## Multi Location Manual AirPrime™ Systems

### Drafting or LDH Intakes

- ▶ Perfect for Front, Rear, Left and Right side intakes on midship pumps
- ▶ Utilize multiple folding tanks during tanker shuttles
- ▶ Quick and Easy transition from tank to pump operation to a drafting operation with external suction intake
- ▶ AirPrime quickly removes entrapped air prior to opening an LDH intake valve
- ▶ When the fire pump is being supplied from the tank water, the pump operator can pre-prime external suction intakes using **PUSH TO PRIME** buttons

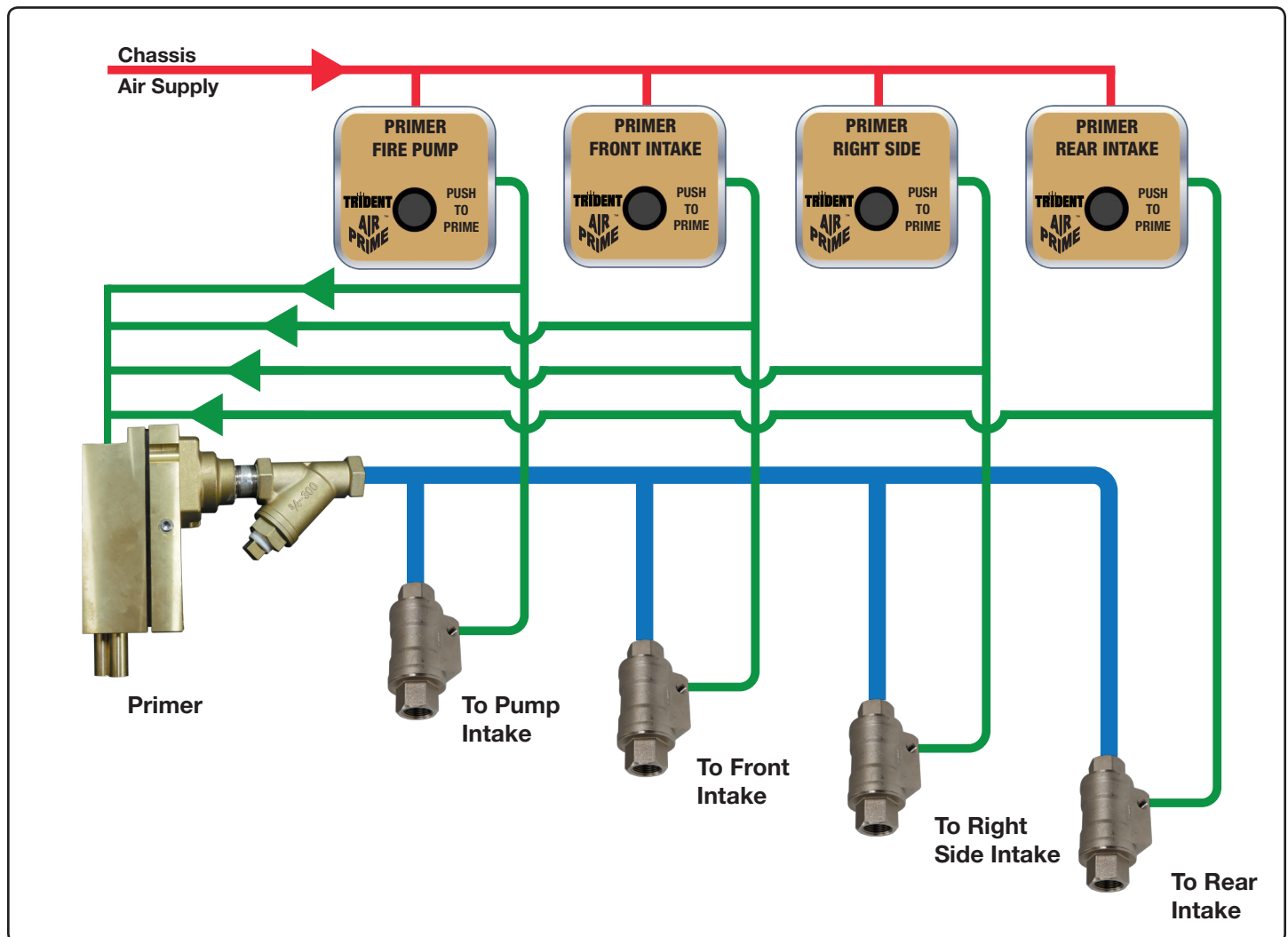

## AirPrime Models

Part Number	Part Number	Panel Control	Locations	Size	Mounting	Compressor
Standard Model	Model With Lift Gauge	Control Type	Number of Priming Points	Number of Barrels	¾" NPT for any Pump or Direct Mount Hale Pump	Minimum CFM Rating
<b>Automatic – Single Location – 2 Barrel</b>						
31.003.5	31.013.5	Switch, 12-Volt	Pump Only	2 Barrel	Any Pump, Remote Mount	13.2 CFM
31.003.6	31.013.6	Switch, 24-Volt	Pump Only	2 Barrel	Any Pump, Remote Mount	13.2 CFM
<b>Automatic – Single Location – 3 Barrel</b>						
31.001.3	31.011.3	Switch, 12-Volt	Pump Only	3 Barrel	Any Pump, Remote Mount	15.6 CFM
31.001.4	31.011.4	Switch, 24-Volt	Pump Only	3 Barrel	Any Pump, Remote Mount	15.6 CFM
31.001.0	31.011.0	Switch, 12-Volt	Pump Only	3 Barrel	Hale-Midship Direct Mount	15.6 CFM
31.001.1	31.011.1	Switch, 24-Volt	Pump Only	3 Barrel	Hale-Midship Direct Mount	15.6 CFM
<b>Automatic – Multiple Location</b>						
31.001.21	31.011.21	Switch, 12-Volt	2 Location	3 Barrel	Any Pump, Remote Mount	15.6 CFM
31.001.22	31.011.22	Switch, 12-Volt	3 Location	3 Barrel	Any Pump, Remote Mount	15.6 CFM
31.001.23	31.011.23	Switch, 12-Volt	4 Location	3 Barrel	Any Pump, Remote Mount	15.6 CFM
<b>Manual – Single Location – 2 Barrel</b>						
31.003.7	31.013.7	Push Button	Pump Only	2 Barrel	Any Pump, Remote Mount	13.2 CFM
31.003.2	31.013.2	Push Button	Pump Only	2 Barrel	Hale-Midship Direct Mount	13.2 CFM
<b>Manual – Single Location – 3 Barrel</b>						
31.001.7	31.011.7	Push Button	Pump Only	3 Barrel	Any Pump, Remote Mount	15.6 CFM
31.001.2	31.011.2	Push Button	Pump Only	3 Barrel	Hale-Midship Direct Mount	15.6 CFM
<b>Manual – Multiple Location – 3 Barrel</b>						
31.001.11	31.011.11	Push Button	2 Location	3 Barrel	Any Pump, Remote Mount	15.6 CFM
31.001.12	31.011.12	Push Button	3 Location	3 Barrel	Any Pump, Remote Mount	15.6 CFM
31.001.13	31.011.13	Push Button	4 Location	3 Barrel	Any Pump, Remote Mount	15.6 CFM
<b>Industrial Automatic AirPrime</b>						
31.013.44	31.013.43	Switch, 12-Volt	To 3000 GPM	2x2 Barrel	Any Pump, Remote Mount	>20 CFM
Not Available	31.013.42	Switch, 12-Volt	Over 3000 GPM	3x2 Barrel	Any Pump, Remote Mount	>30 CFM
<b>Vehicles Without Air Brakes - AirPrime SC</b>						
Contact Trident for Information on Using AirPrime on NFPA 1901 and 1906 vehicles without air brakes.						

<b>AirPrime Conversion Kits ( Not Shown)</b>	
<b>Conversion Kit: Single Location AirPrime System, Converts Manual to Automatic</b>	27.014.0
<b>Conversion Kit: Multi-Location AirPrime System, Converts Manual to Automatic</b>	27.014.1
<b>Conversion Kit: Manual AirPrime System, Converts Single (1) Location to Dual (2) Location</b>	27.005.2
<b>Conversion Kit: Automatic AirPrime System, Converts Single (1) Location to Dual (2) Location</b>	27.005.3
<b>Conversion Kit: Multi-Location AirPrime System, Adds Additional Locations Going From (2) to (3) Locations. Or From (3) to (4) Locations</b>	27.005.1
<b>Conversion Kit: Manual AirPrime System, Adding Lift Gauge to Panel Control Note: See Page 3 to view 1/8" NPT Port. Contact Factory for Info.</b>	27.005.4
<b>Conversion Kit: Auto AirPrime System, Adding Lift Gauge to Panel Control Note: See Page 3 to view 1/8" NPT Port. Contact Factory for Info.</b>	27.005.5
<b>Conversion Kit: Manual AirPrime System, Converting to Auto with Lift Gauge Note: See Page 3 to view 1/8" NPT Port. Contact Factory for Info.</b>	27.005.6
<b>Rebuild Kit: Contains Seals, Spring, Check Valve Plate, Mesh Inlet Filter, Fasteners</b>	27.003.3

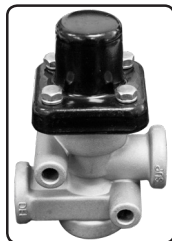

Optional Air Pressure Protection Valve

◀ Part# 30.053.0

Direct Mount AirPrime™ ▶



All AirPrime™ models are covered by US Patent # 6,682,313



### 2 Barrel Design

13.2 CFM Minimum Air Compressor Rating  
1000 GPM or Less Fire Pump Rating

### 3 Barrel Design

15.6 CFM Minimum Air Compressor Rating  
1250 GPM or Larger Fire Pump Rating

### Industrial AirPrime

Up To 3000 GPM requires >20 CFM  
Over 3000 GPM requires >30 CFM

## Trident Emergency Products, LLC

2940 Turnpike Drive | Suite #9 | Hatboro, PA 19040 USA  
215-293-0700 Phone  
215-293-0701 Fax  
sales@tridentdirect.com Email

**TridentDirect.com**

Document #02.003.1 • 07/10/2019

<https://www.facebook.com/tridentemergency>



World Class Fire Industry Products

AirPrime™ is a trademark of Trident Emergency Products, LLC